

Hydro Solo-E with CRE 10

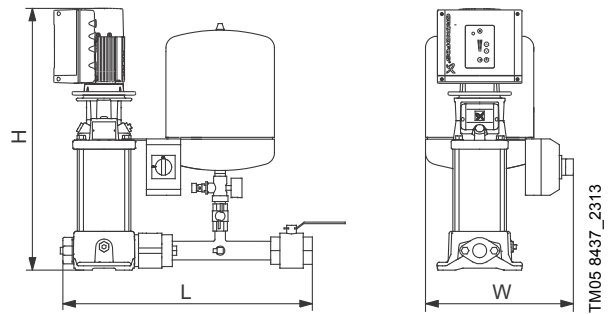
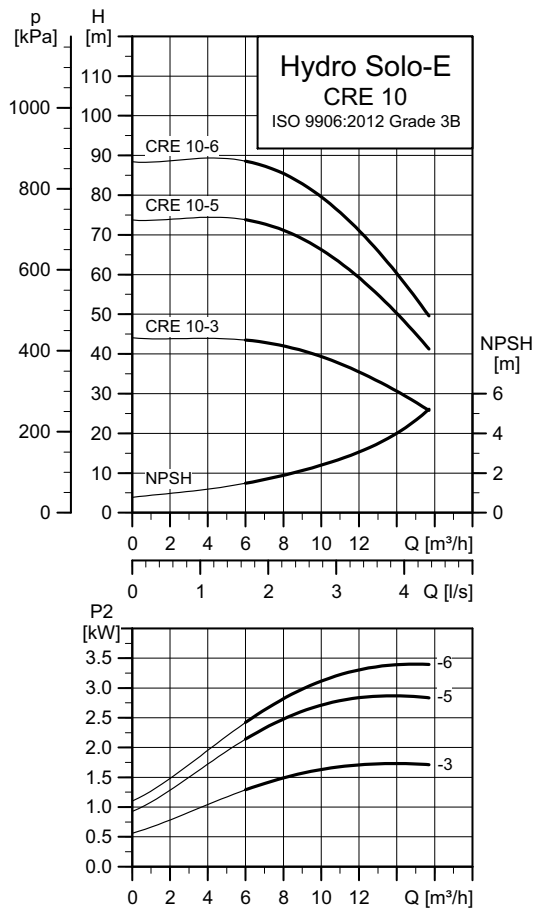

Electrical data, dimensions and weights

International range

Pump type	Motor [kW]	Full-load current [A]	Supply voltage [V]	Tank volume [m ³]	Connection inlet/outlet	Weight [kg]		Packing [m ³]	Total height [mm]	Dimensions		
						Net weight	Gross weight			A [mm]	H [mm]	L [mm]
CRE 10-1	0.75	4.70 - 3.90	1 x 200-240	18	Rp 1" 1/2	58	61	0.6	561	425	561	650
CRE 10-3	2.2	4.15 - 3.40	3 x 380-500	18	Rp 1" 1/2	62	89	0.6	667	425	667	650
CRE 10-5	3	6.20 - 5.00	3 x 380-500	33	Rp 1" 1/2	83	86	0.6	793	425	793	650
CRE 10-6	4	7.60 - 6.20	3 x 380-500	12	Rp 1" 1/2	78	103	0.6	822	400	822	705

Southern European range

Pump type	Motor [kW]	Full-load current [A]	Supply voltage [V]	Tank volume [m ³]	Connection inlet/outlet	Weight [kg]		Packing [m ³]	Total height [mm]	Dimensions		
						Net weight	Gross weight			A [mm]	H [mm]	L [mm]
CRE 10-1	0.75	4.70 - 3.90	1 x 200-240	25	Rp 1" 1/2	67	87	0.6	561	425	561	650
CRE 10-3	2.2	4.15 - 3.40	3 x 380-480	25	Rp 1" 1/2	75	95	0.6	667	425	667	650
CRE 10-5	3	6.20 - 5.0	3 x 380-480	25	Rp 1" 1/2	93	113	0.6	793	425	793	650
CRE 10-6	4	8.10 - 6.60	3 x 380-480	25	Rp 1" 1/2	105	125	0.6	860	425	860	650