

Model #UTP033-2

1/3 HP Submersible Utility Pump

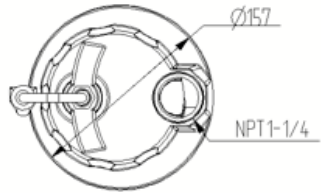
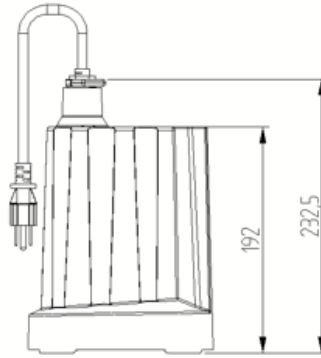

Inlet	Diameter 14.4 inches
Discharge	NH3/4
Pump Cover	PA66-GF25
Motor Housing	ZL104+DMC
Pump Body	PP-GF30
Switch Type	/
Impeller	PPO-GF30
Seal Design	Framework oil seal
Seal Material	NBR
Oil Filled Motor	Yes
Power Cord	SJTW 18AWG 10ft
Net Weight	8.2
Gross Weight	9.5
Package Size	7.5*6.5*11
Expected Life Cycle	4000 Hours
Motor Wires	Copper
Self-Priming	/
Certification	UL

Features & Benefits:

- ❖ Continuous duty and easy access handle for portability.
- ❖ Corrosion-resistant, reinforced thermoplastic construction.
- ❖ Bottom suction design filters debris and removes water down to 1/4" from surface.
- ❖ Built-in automatic thermal overload protector motor.
- ❖ 3/4" NPT discharge, 1 1/4" adapter included.
- ❖ Top discharge design.
- ❖ 10ft power cord.
- ❖ 1 year warranty.

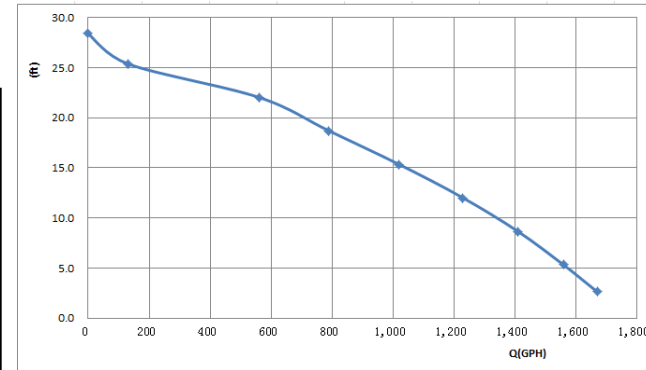

Model	HP	Voltage	AMP	Discharge NPT(In)	GPH of water @ Total Ft. of Head					Max.Head Ft
					5 ft	10 ft	15 ft	20 ft	25 ft	
UTP033-2	1/3	115	4	1-1/4	2160	1950	1700	1450	1100	33.5